

NOTES:

- 1) MATERIALS:
HOUSING: GLASS FILLED POLYESTER, UL94 V-0, COLOR: BLACK
TERMINALS: PHOSPHOR BRONZE
- 2) FINISH:
TERMINALS:
(A) SELECT GOLD IN CONTACT AREA: 50 MICROINCHES (1.27 MICROMETERS) MIN.,
*SELECT TIN IN PC TAIL AREA: 100 MICROINCHES (2.54 MICROMETERS) MIN.,
WITH OVERALL NICKEL UNDERPLATE: 50 MICROINCHES (1.27 MICROMETERS) MIN.
(B) SELECT GOLD IN CONTACT AREA: 30 MICROINCHES (0.76 MICROMETERS) MIN.,
*SELECT TIN IN PC TAIL AREA: 100 MICROINCHES (2.54 MICROMETERS) MIN.,
WITH OVERALL NICKEL UNDERPLATE: 50 MICROINCHES (1.27 MICROMETERS) MIN.
(C) SELECT GOLD IN CONTACT AREA: 15 MICROINCHES (0.38 MICROMETERS) MIN.,
*SELECT TIN IN PC TAIL AREA: 100 MICROINCHES (2.54 MICROMETERS) MIN.,
WITH OVERALL NICKEL UNDERPLATE: 50 MICROINCHES (1.27 MICROMETERS) MIN.
*THE PRIMARY SHIPPING CARTON WILL BE LABELED 'COMPLIANT TO RoHS'
DIRECTIVE 2002/95/EC AND ELV ANNEX II OF DIRECTIVE 2000/53/EC.'
CARTONS WITHOUT THIS LABEL MAY CONTAIN PRODUCT WITH TIN-LEAD
IN THE PC TAIL AREA.
- 3) ALL JACKS MUST MEET THE REQUIREMENTS OF MOLEX SPECIFICATION #PS-41314.
- 4) PACKAGING OPTIONS: THERMOFORMED TRAYS PER PK-41369-004 OR TUBES PER PK-41369-005
- 5) JACKS CONFORM TO AND ACCEPT PLUGS WHICH CONFORM TO FCC REGULATIONS, PART 68.5.
- 6) JACKS ARE TO BE USED WITH .062/(1.57) THICK PRINTED CIRCUIT BOARDS.
- 7) SEE SHEET 3 FOR RECOMMENDED PANEL CUT-OUT AND BOARD LAYOUT DIMENSIONS.
- 8) PANEL TO BE LOCATED AGAINST MODULAR JACK FLANGE AS INDICATED.
- 9) ALL UNTOLERANCED DIMENSIONS ARE SHOWN FOR REFERENCE ONLY.

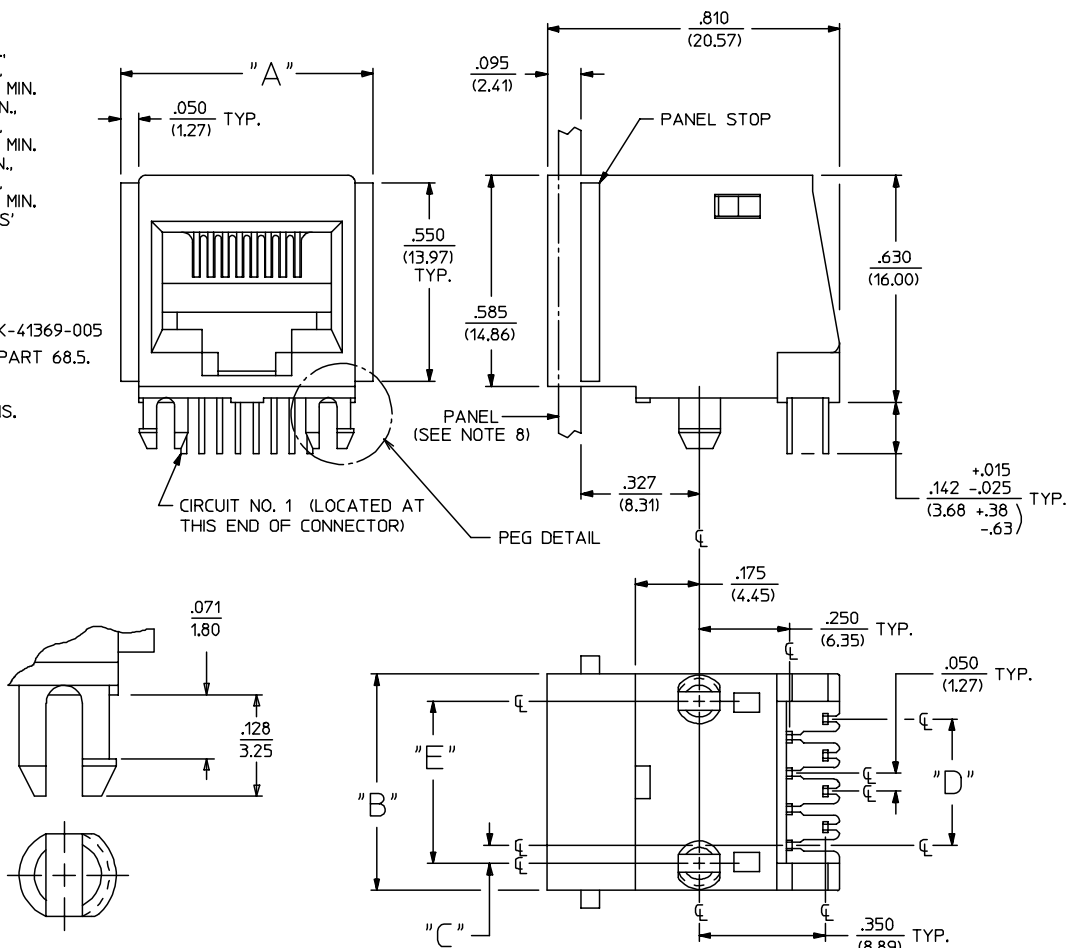

PEG DETAIL
SCALE: 8:1

SIZE 8 MODULAR JACK HOUSING LOADED WITH 8 TERMINALS IS SHOWN ABOVE

REMOVE FILM/AMMO PACK FC NO. UCP2006-2453 DRAWN: PRDERR 2006/06/14 CHKD: LSCHMDT 2006/06/27 APPR: FSMITH 2006/06/29	QUALITY SYMBOLS	GENERAL TOLERANCES (UNLESS SPECIFIED)	SCALE 4:1	DESIGN UNITS INCH	THIRD ANGLE PROJECTION	REVISE ON CAD ONLY
	DESCRIPTION	mm	INCH	DIMENSION STYLE IN/MM	TITLE RIGHT ANGLE FLUSH MOUNT MODULAR JACK ASSEMBLY	
		4 PLACES ± --- ± ---	3 PLACES ± --- ± ---	DRAWN BY DATE GLT 1990/05/09		
		2 PLACES ± --- ± ---	1 PLACE ± --- ± ---	CHECKED BY DATE BAP 1990/05/09		
APPROVED BY DATE RAS 1990/05/09	ANGULAR ±1/2°	DRAFT WHERE APPLICABLE	MATERIAL NO.	DOCUMENT NO.	SHEET NO.	
V1		MUST REMAIN WITHIN DIMENSIONS	THIS DRAWING CONTAINS INFORMATION THAT IS PROPRIETARY TO MOLEX INCORPORATED AND SHOULD NOT BE USED WITHOUT WRITTEN PERMISSION		SEE SHEET 2	1 OF 3

3	V
2	V1
1	V1
SH	REV

8	2	.700 (17.78)	.600 (15.24)	.200 (5.08)	.050 (1.27)	.450 (11.43)
8	4	.700 (17.78)	.600 (15.24)	.150 (3.81)	.150 (3.81)	.450 (11.43)
8	6	.700 (17.78)	.600 (15.24)	.100 (2.54)	.250 (6.35)	.450 (11.43)
8	8	.700 (17.78)	.600 (15.24)	.050 (1.27)	.350 (8.89)	.450 (11.43)
6	2	.620 (15.75)	.520 (13.21)	.175 (4.45)	.050 (1.27)	.400 (10.16)
6	4	.620 (15.75)	.520 (13.21)	.125 (3.18)	.150 (3.81)	.400 (10.16)
6	6	.620 (15.75)	.520 (13.21)	.075 (1.91)	.250 (6.35)	.400 (10.16)
4	2	.540 (13.72)	.440 (11.18)	.125 (3.18)	.050 (1.27)	.300 (7.62)
4	4	.540 (13.72)	.440 (11.18)	.075 (1.91)	.150 (3.81)	.300 (7.62)

HOUSING SIZE	CIRCUIT SIZE	DIM. "A"	DIM. "B"	DIM. "C"	DIM. "D"	DIM. "E"
--------------	--------------	----------	----------	----------	----------	----------

	13	12	11	10	9	8	7	6	5	4	3	2		
	ENGINEERING PART NUMBER	E.D.P. NUMBER	HOUSING SIZE	CIRCUIT SIZE	PLATING OPTION	PACKAGING OPTION								
J	A-41369-44ABAA	015-43-7544	4	4	(A)	TRAY PACK								J
	A-41369-44CBAA	015-43-7541	4	4	(C)	TRAY PACK								
	A-41369-42ABAA	015-43-7540	4	2	(A)	TRAY PACK								
	A-41369-66ABAA	015-43-7566	6	6	(A)	TRAY PACK								
	A-41369-66BBAA	015-43-7567	6	6	(B)	TRAY PACK								
	A-41369-64ABAA	015-43-7564	6	4	(A)	TRAY PACK								
	A-41369-64BBAA	015-43-7565	6	4	(B)	TRAY PACK								
I	A-41369-62ABAA	015-43-7563	6	2	(A)	TRAY PACK								I
	A-41369-88ABAA	015-43-7588	8	8	(A)	TRAY PACK								
	A-41369-86ABAA	015-43-7586	8	6	(A)	TRAY PACK								
	A-41369-84ABAA	015-43-7584	8	4	(A)	TRAY PACK								
	A-41369-82ABAA	015-43-7580	8	2	(A)	TRAY PACK								
	A-41369-44ACAA	015-43-7546	4	4	(A)	TUBES								
	A-41369-64ACAA	015-43-7570	6	4	(A)	TUBES								
H	A-41369-62ACAA	015-43-7571	6	2	(A)	TUBES								H
G													G	
F													F	
E													E	
D													D	
C													C	
B													B	
A													A	

SEE SHEET ONE EC NO: UCP2006-2453 DRWN: PRIDDER 2006/06/14 CHKD: LSCHMIDT 2006/06/27 APPR: FSMITH 2006/06/29	QUALITY SYMBOLS	GENERAL TOLERANCES (UNLESS SPECIFIED)	SCALE ---	DESIGN UNITS INCH	THIRD ANGLE PROJECTION	REVISE ON CAD ONLY	
	▽ - 0	mm INCH	DIMENSION STYLE IN/MM	TITLE			
	▽ - 0	4 PLACES ± --- ± --- 3 PLACES ± --- ± --- 2 PLACES ± --- ± --- 1 PLACE ± --- ± ---	DRAWN BY DATE GLT 1990/05/09	RIGHT ANGLE FLUSH MOUNT MODULAR JACK ASSEMBLY			
		ANGULAR ±1/2°	CHECKED BY DATE BAP 1990/05/09	MOLEX INCORPORATED			
	DRAFT WHERE APPLICABLE MUST REMAIN WITHIN DIMENSIONS	APPROVED BY DATE RAS 1990/05/09	MATERIAL NO.	DOCUMENT NO.	SHEET NO.		
		THIS DRAWING CONTAINS INFORMATION THAT IS PROPRIETARY TO MOLEX INCORPORATED AND SHOULD NOT BE USED WITHOUT WRITTEN PERMISSION					

ENGINEERING PART NUMBER	HOUSING SIZE	CIRCUIT SIZE	DIM. "A"	DIM. "B"	DIM. "C"
A-41369-44XXXX	4	4	.455/(11.56)	.300/(7.62)	.150/(3.81)
A-41369-42XXXX	4	2	.455/(11.56)	.300/(7.62)	.050/(1.27)
A-41369-66XXXX	6	6	.535/(13.59)	.400/(10.16)	.250/(6.35)
A-41369-64XXXX	6	4	.535/(13.59)	.400/(10.16)	.150/(3.81)
A-41369-62XXXX	6	2	.535/(13.59)	.400/(10.16)	.050/(1.27)
A-41369-88XXXX	8	8	.615/(15.62)	.450/(11.43)	.350/(8.89)
A-41369-86XXXX	8	6	.615/(15.62)	.450/(11.43)	.250/(6.35)
A-41369-84XXXX	8	4	.615/(15.62)	.450/(11.43)	.150/(3.81)
A-41369-82XXXX	8	2	.615/(15.62)	.450/(11.43)	.050/(1.27)

NOTE: ALL RECOMMENDED BOARD LAYOUTS ARE SHOWN AS COMPONENT SIDE OF BOARD

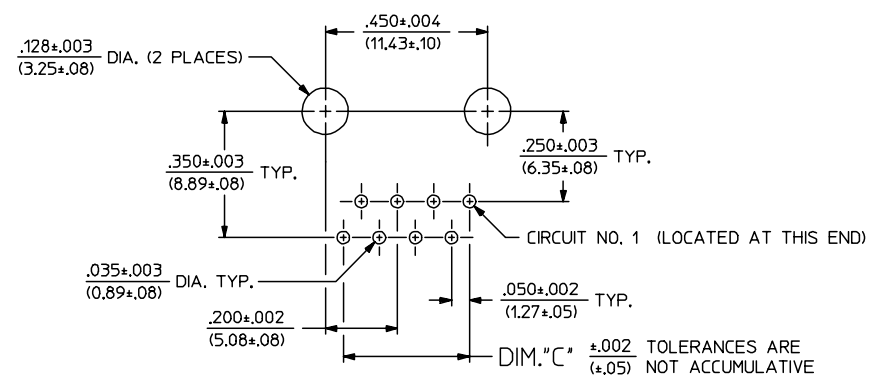

PC BOARD LAYOUT FOR HOUSING SIZE 8

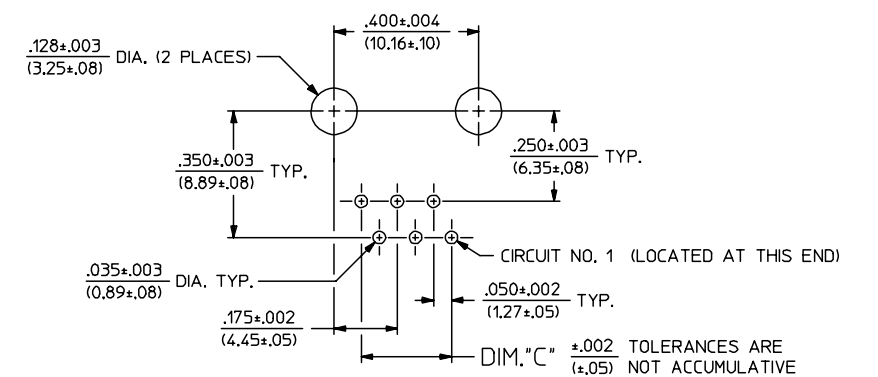

PC BOARD LAYOUT FOR HOUSING SIZE 6

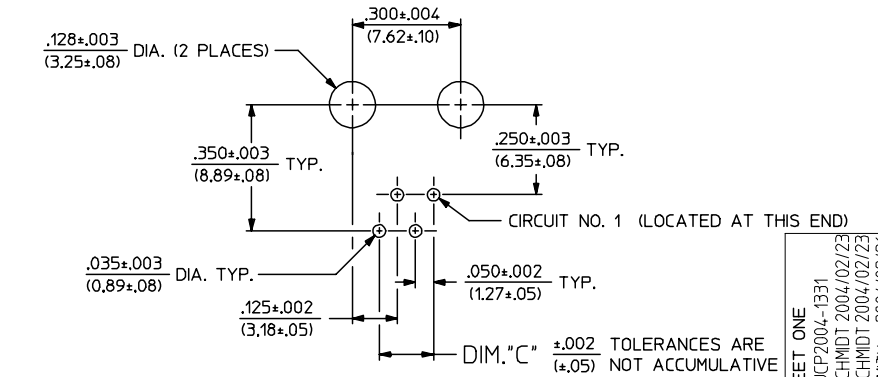

PC BOARD LAYOUT FOR HOUSING SIZE 4

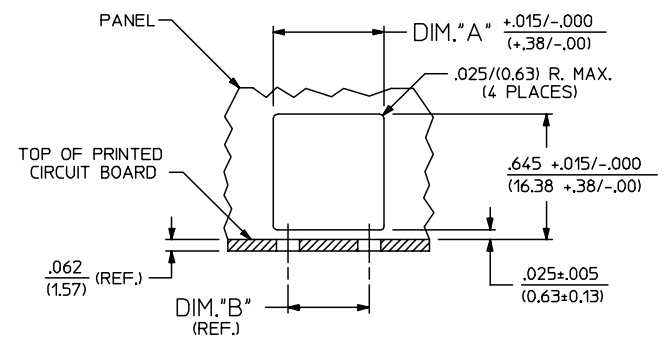

PANEL CUT-OUT GUIDELINES
DIM. "A" MUST BE SYMMETRICAL TO DIM. "B" WITHIN .005/(0.13)

SEE SHEET ONE
EC NO: UCP2004-1331
DRAWN:LSCHMIDT 2004/02/23
CHKD:LSCHMIDT 2004/02/23
APPR:FSMITH 2004/02/26
REV

QUALITY SYMBOLS	DESCRIPTION
▽ = 0	
▽ = 0	

GENERAL TOLERANCES (UNLESS SPECIFIED)	
mm	INCH
4 PLACES ± ---	± ---
3 PLACES ± ---	± ---
2 PLACES ± ---	± ---
1 PLACE ± ---	± ---
ANGULAR ±1/2°	
DRAFT WHERE APPLICABLE MUST REMAIN WITHIN DIMENSIONS	

SCALE 4:1	DESIGN UNITS INCH
DIMENSION STYLE IN/MM	
DRAWN BY GLT	DATE 1990/05/09
CHECKED BY BAP	DATE 1990/05/09
APPROVED BY RAS	DATE 1990/05/09

THIRD ANGLE PROJECTION	REVISE ON CAD ONLY
TITLE PANEL/BOARD LAYOUTS FOR RIGHT ANGLE FLUSH MOUNT MODULAR JACK ASSEMBLIES	
MOLEX MOLEX INCORPORATED	
MATERIAL NO. SEE SHEET 2	DOCUMENT NO. SDA-41369-*****
SHEET NO. 3 OF 3	